



TM40P04DF

P -Channel Enhancement Mosfet

<p>General Description</p> <ul style="list-style-type: none"> • Low $R_{DS(ON)}$ • RoHS and Halogen-Free Compliant <p>Applications</p> <ul style="list-style-type: none"> • Load switch • PWM 	<p>General Features</p> <p>$V_{DS} = -40V$ $I_D = -40A$</p> <p>$R_{DS(ON)} = 10m\Omega$(typ.) @ $V_{GS} = -10V$</p> <p>100% UIS Tested 100% R_g Tested</p> 
--	--

DF:DFN3x3-8L

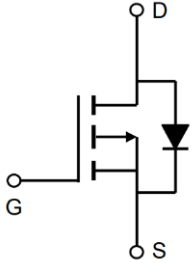
Marking: 40P04

Absolute Maximum Ratings ($T_A = 25^\circ C$, unless otherwise noted)

Parameter	Symbol	Value	Unit
Drain-Source Voltage	V_{DS}	-40	V
Gate-Source Voltage	V_{GS}	± 20	V
Continuous Drain Current	I_D	$T_C = 25^\circ C$	-40
		$T_C = 100^\circ C$	-28
Pulsed Drain Current ¹	I_{DM}	-144	A
Single Pulse Avalanche Energy ²	EAS	80	mJ
Total Power Dissipation	$T_C = 25^\circ C$	P_D	21
Operating Junction and Storage Temperature Range	T_J, T_{STG}	-55 to 150	$^\circ C$

Thermal Characteristics

Parameter	Symbol	Value	Unit
Thermal Resistance from Junction-to-Ambient ³	$R_{\theta JA}$	64.3	$^\circ C/W$
Thermal Resistance from Junction-to-Case	$R_{\theta JC}$	6	$^\circ C/W$

Electrical Characteristics (T_J = 25°C, unless otherwise noted)

Parameter	Symbol	Test Conditions	Min.	Typ.	Max.	Unit	
Static Characteristics							
Drain-Source Breakdown Voltage	V_{(BR)DSS}	V _{GS} = 0V, I _D = -250μA	-40	-	-	V	
Gate-body Leakage current	I_{GSS}	V _{DS} = 0V, V _{GS} = ±20V	-	-	±100	nA	
Zero Gate Voltage Drain Current	I_{DSS}	V _{DS} = -40V, V _{GS} = 0V	T _J =25°C	-	-	1	μA
			T _J =100°C	-	-	5	
Gate-Threshold Voltage	V_{GS(th)}	V _{DS} = V _{GS} , I _D = -250μA	-1.0	-1.6	-2.5	V	
Drain-Source On-Resistance ⁴	R_{DS(on)}	V _{GS} = -10V, I _D = -16A	-	10	13	mΩ	
		V _{GS} = -4.5V, I _D = -12A	-	14	20		
Forward Transconductance ⁴	g_{fs}	V _{DS} = -10V, I _D = -16A	-	44	-	S	
Dynamic Characteristics⁵							
Input Capacitance	C_{iss}	V _{DS} = -20V, V _{GS} = 0V, f = 1MHz	-	3050	-	pF	
Output Capacitance	C_{oss}		-	282	-		
Reverse Transfer Capacitance	C_{rss}		-	230	-		
Gate Resistance	R_g	f = 1MHz	-	9	-	Ω	
Switching Characteristics⁵							
Total Gate Charge	Q_g	V _{GS} = -10V, V _{DS} = -20V, I _D = -16A	-	28	-	nC	
Gate-Source Charge	Q_{gs}		-	8	-		
Gate-Drain Charge	Q_{gd}		-	8.5	-		
Turn-on Delay Time	t_{d(on)}	V _{GS} = -10V, V _{DD} = -15V, R _G = 3Ω, I _D = -16A	-	38	-	ns	
Rise Time	t_r		-	31	-		
Turn-off Delay Time	t_{d(off)}		-	90	-		
Fall Time	t_f		-	9.2	-		
Drain-Source Body Diode Characteristics							
Diode Forward Voltage ⁴	V_{SD}	I _S = -1A, V _{GS} = 0V	-	-	-1.2	V	
Continuous Source Current	I_S	T _C =25°C	-	-	-30	A	

Notes:

1. Repetitive rating, pulse width limited by junction temperature T_{J(MAX)}=150°C.
2. The EAS data shows Max. rating . The test condition is V_{DD}= -25V, V_{GS}= -10V, L=0.1mH, I_{AS}= -40A.
3. The data tested by surface mounted on a 1 inch² FR-4 board with 2OZ copper, The value in any given application depends on the user's specific board design.
4. The data tested by pulsed , pulse width ≤ 300us , duty cycle ≤ 2%.
5. This value is guaranteed by design hence it is not included in the production test..

Typical Characteristics

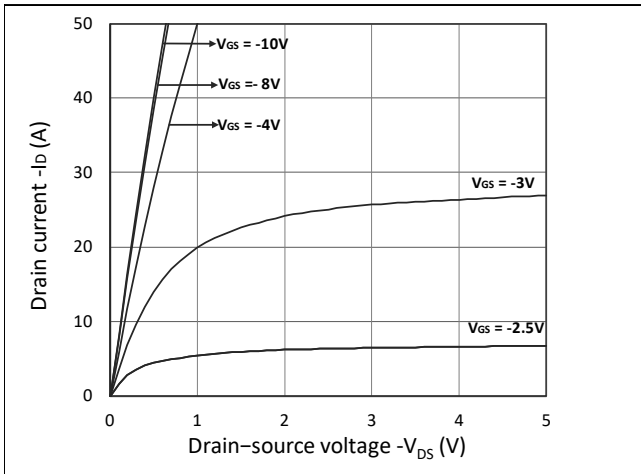

Figure 1. Output Characteristics

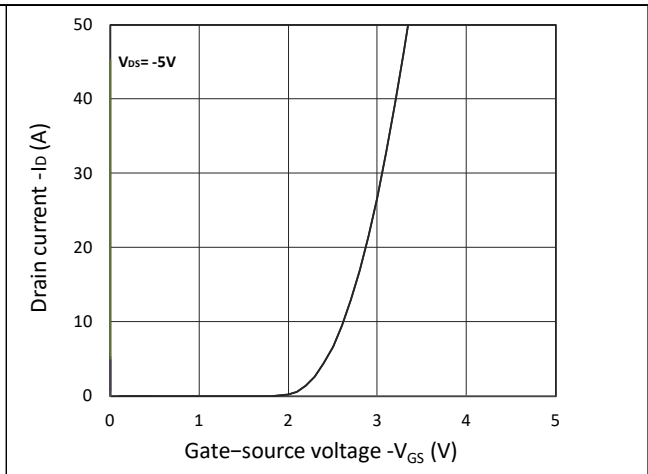

Figure 2. Transfer Characteristics

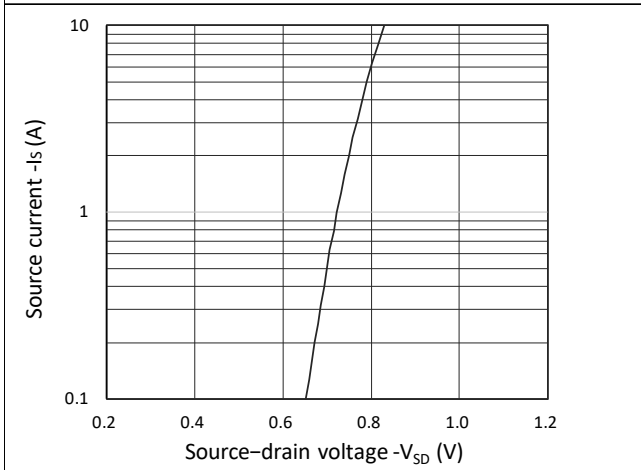

Figure 3. Forward Characteristics of Reverse

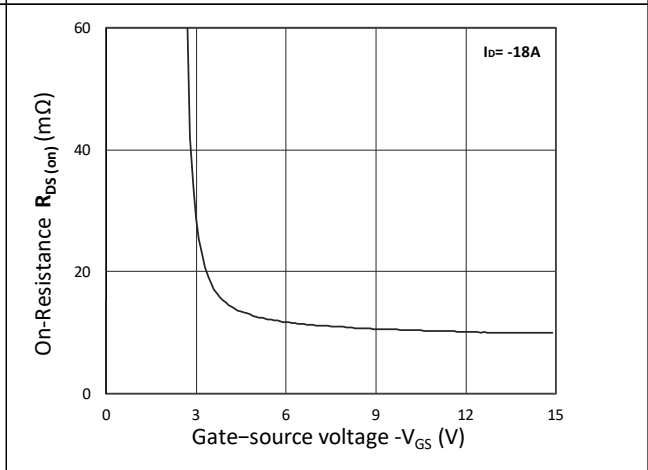

Figure 4. $R_{DS(on)}$ vs. V_{GS}

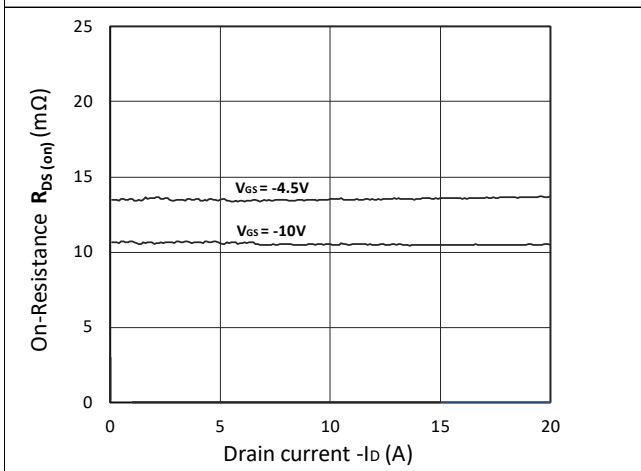

Figure 5. $R_{DS(on)}$ vs. I_D

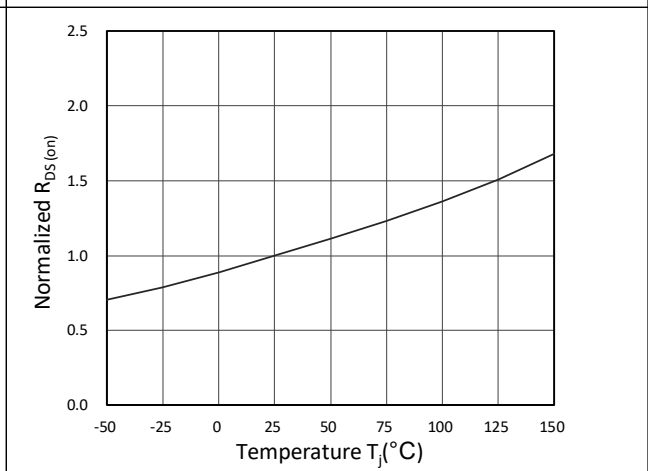

Figure 6. Normalized $R_{DS(on)}$ vs. Temperature

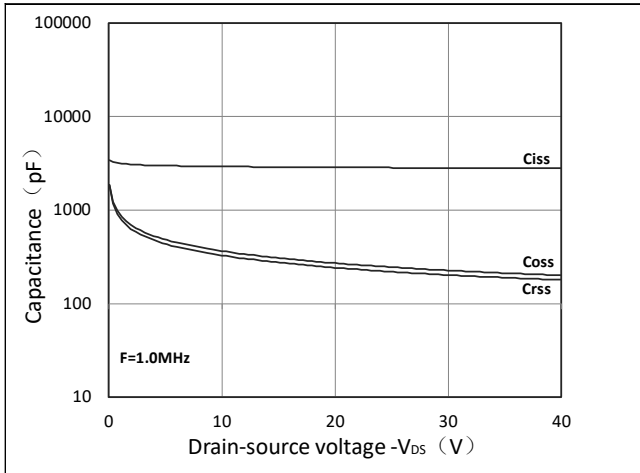

Figure 7. Capacitance Characteristics

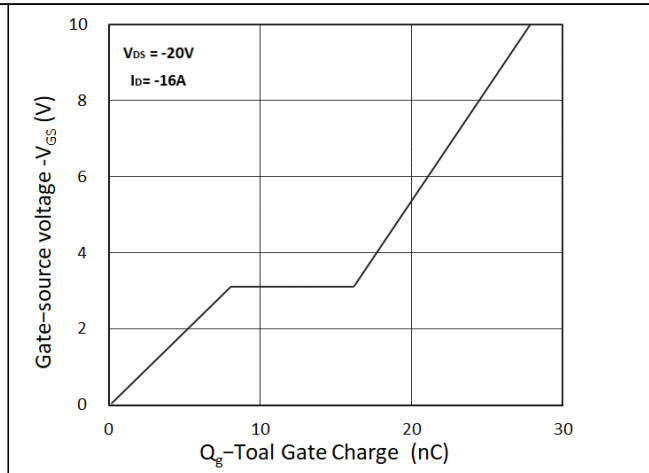

Figure 8. Gate Charge Characteristics

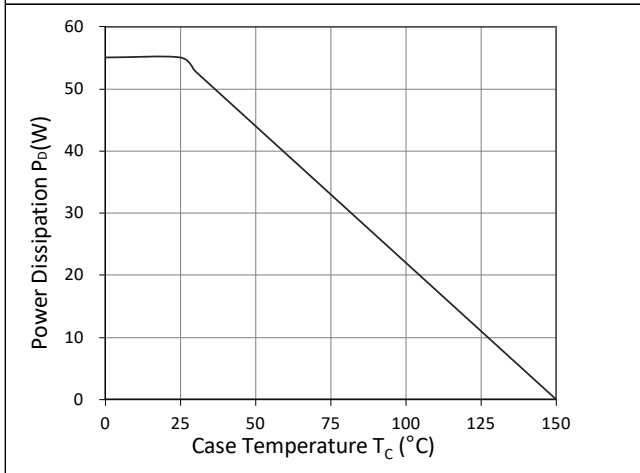

Figure 9. Power Dissipation

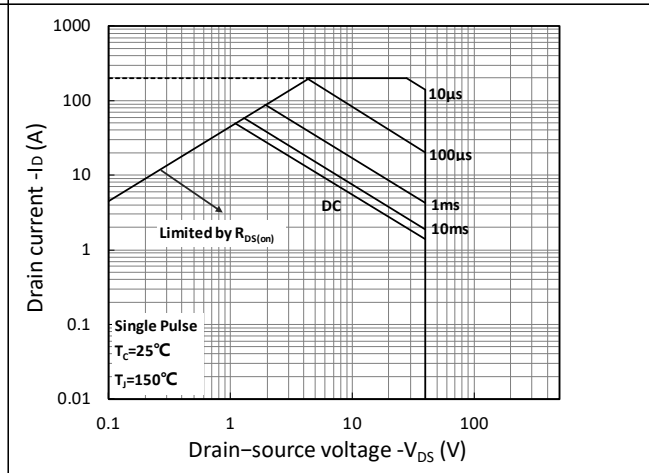

Figure 10. Safe Operating Area

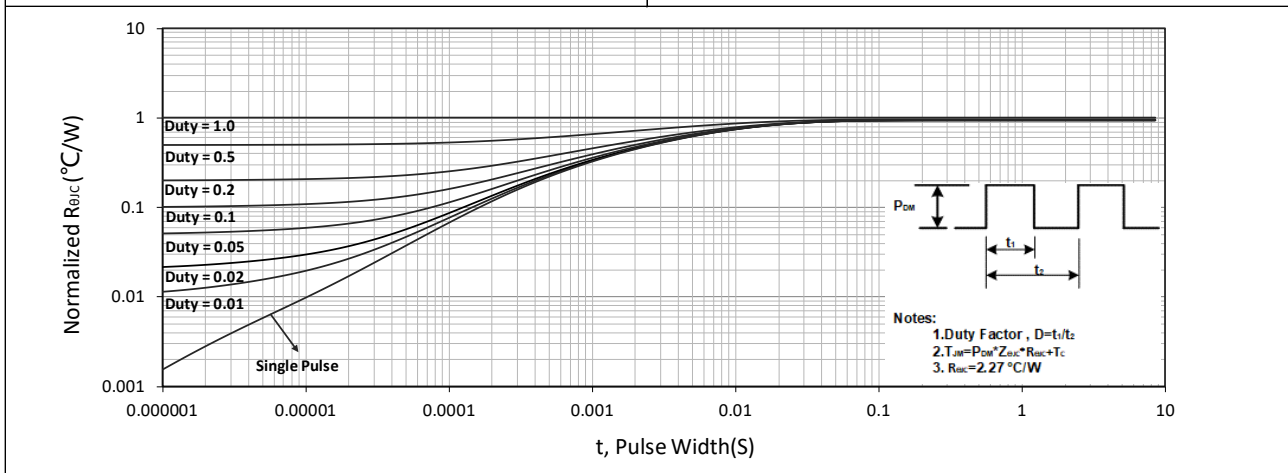

Figure 11. Normalized Maximum Transient Thermal Impedance

Test Circuit

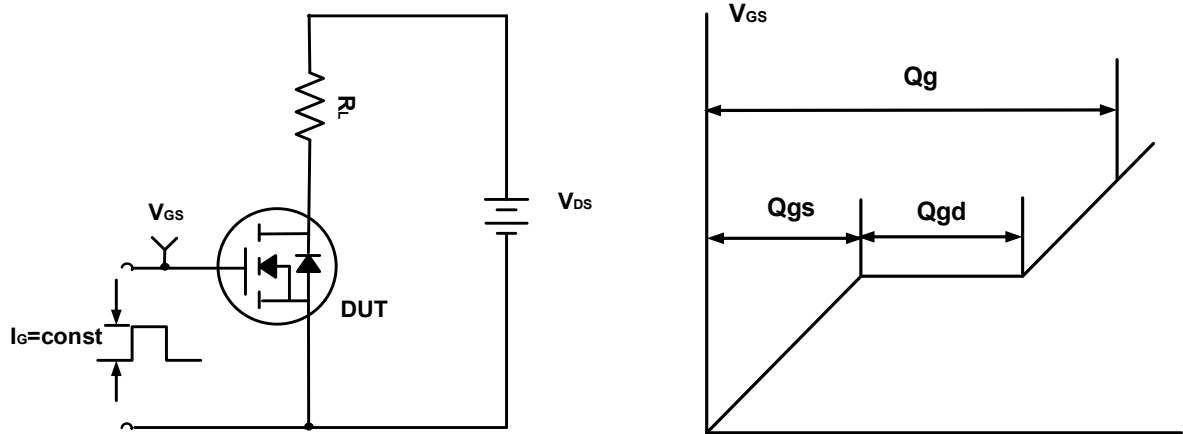

Figure A. Gate Charge Test Circuit & Waveforms

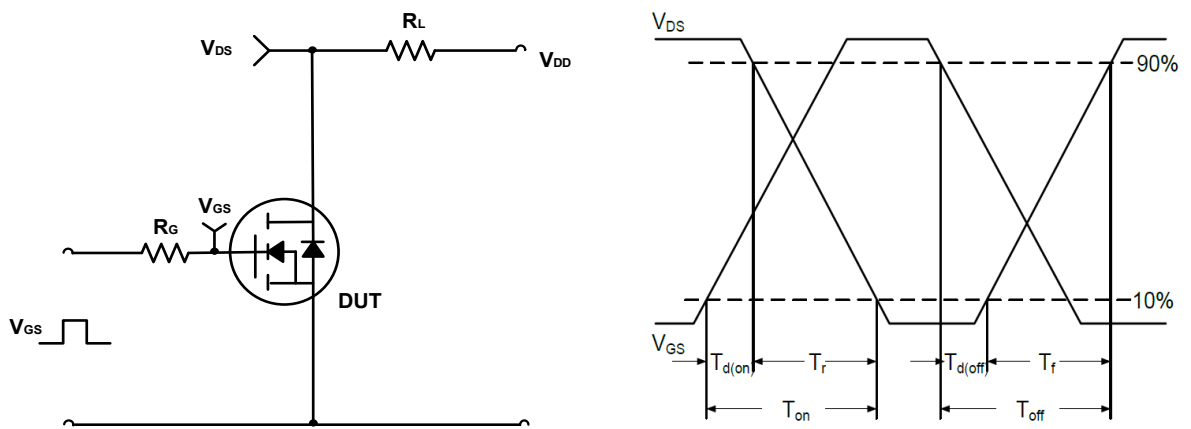

Figure B. Switching Test Circuit & Waveforms

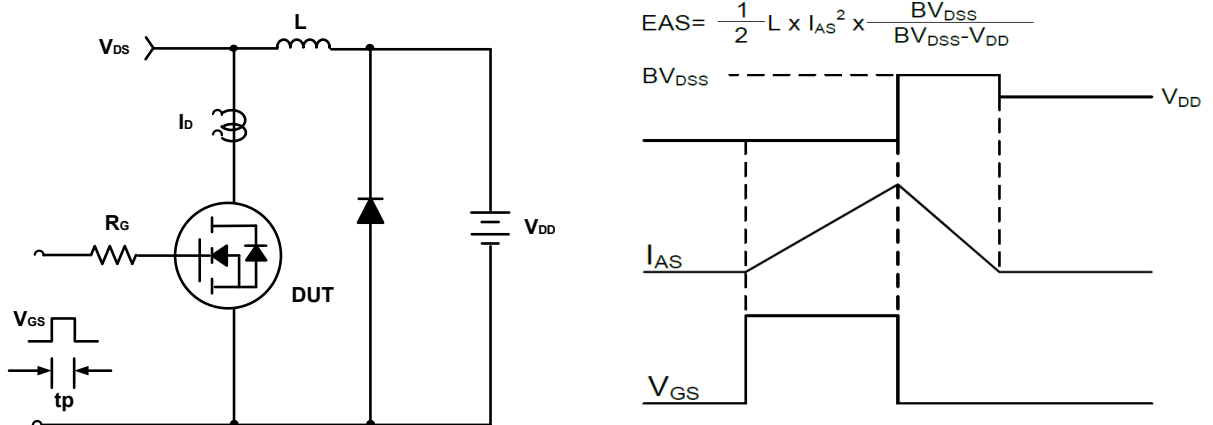
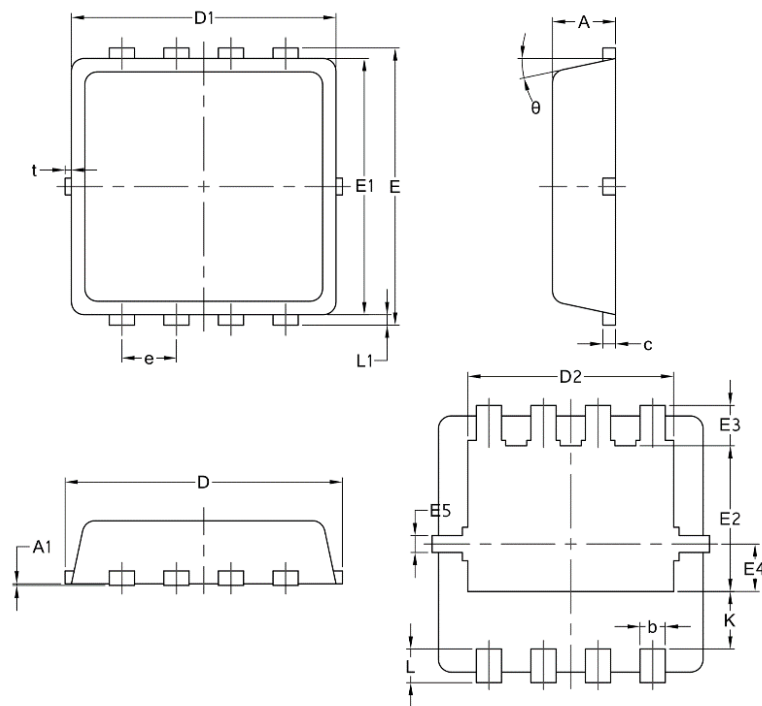

Figure C. Unclamped Inductive Switching Circuit & Waveforms

Package Mechanical Data:DFN3x3-8L



Symbol	Common		
	mm		
	Mim	Nom	Max
A	0.70	0.75	0.85
A1	/	/	0.05
b	0.20	0.30	0.40
c	0.10	0.152	0.25
D	3.15	3.30	3.45
D1	3.00	3.15	3.25
D2	2.29	2.45	2.65
E	3.15	3.30	3.45
E1	2.90	3.05	3.20
E2	1.54	1.74	1.94
E3	0.28	0.48	0.65
E4	0.37	0.57	0.77
E5	0.10	0.20	0.30
e	0.60	0.65	0.70
K	0.59	0.69	0.89
L	0.30	0.40	0.50
L1	0.06	0.125	0.20
t	0	0.075	0.13
Φ	10	12	14